









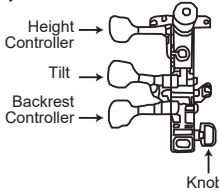
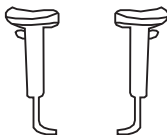
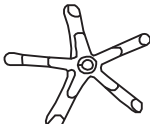

# PARTS

|  |   |   |  |  |  |
|--|---|---|--|--|--|
| <p><b>(1)x1</b></p>  <p>Chair Back</p>        | <p><b>(2)x1</b></p>  <p>Seat</p>           | <p><b>(3)x1</b></p>  <p>Lift Mechanism</p> | <p><b>(4)x2</b></p>  <p>Arm 4A Arm 4B</p>  | <p><b>(5)x1</b></p>  <p>Base</p>          | <p><b>(6)x5</b></p>  <p>Caster</p>      |
| <p><b>(7)x1</b></p>  <p>Gas Lift Cylinder</p> | <p><b>(8)x1</b></p>  <p>Cylinder Cover</p> | <p><b>(9)x10</b></p>  <p>M6 x 25 Bolt</p>  | <p><b>(10)x10</b></p>  <p>M6 x 16 Bolt</p> | <p><b>(11)x1</b></p>  <p>Allen Wrench</p> | <p><b>(12)x1</b></p>  <p>Dust Cover</p> |

## STEP 1

**STEP 1:** Attach Arm 4A and 4B (Part 4) to the underside of the Seat (Part 2) using 3 M6 x 25 Bolt (Part 9) and 3 M6 x 16 Bolt (Part 10).

\*Note: **TIGHTEN THE BOLTS COMPLETELY.**

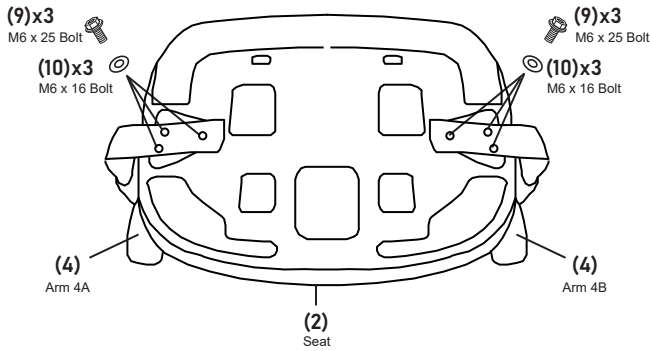

## STEP 2

**STEP 2:** Attach Lift Mechanism (Part 3) to the underside of the Seat (Part 2) using 4 M6 x 25 Bolt (Part 9) and 4 M6 x 16 Bolt (Part 10).

\*Note: **TIGHTEN THE BOLTS COMPLETELY.**

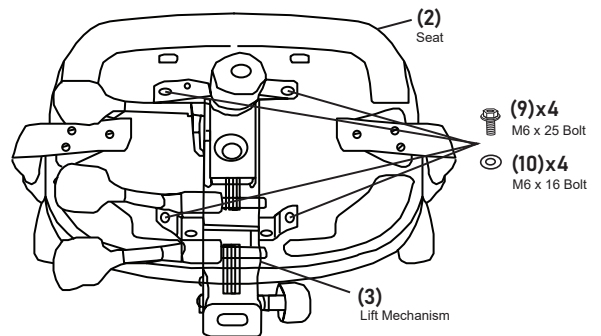

## STEP 3

**STEP 3A:** Place Cylinder Cover (Part 8) over Gas Lift Cylinder (Part 7) then insert Gas Lift Cylinder (Part 7) into the Base (Part 5).

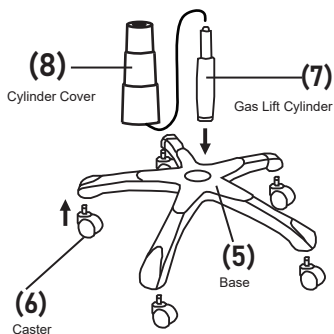

**Step 3B:** Attach Gas Lift Cylinder (Part 7) and 5 casters (Part 6) into the Base (Part 5)

## STEP 4

**STEP 4:** Place Seat (Part 2) onto the Gas Lift Cylinder (Part 7).

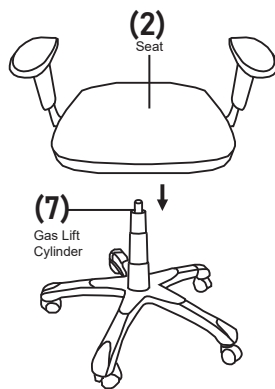

## STEP 5

**STEP 5A:** Assemble the Chair back (Part 1) and seat (Part 2) as shown below.

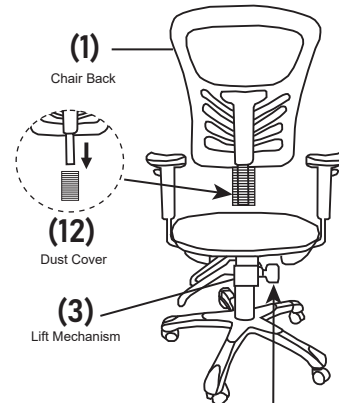

**STEP 5B:** Insert the Chair back (Part 1) into the Lift mechanism (Part 3) and adjust to desired height, turn the knob clockwise until it is screwed in tightly.

## STEP 6

